



CORRIGÉ

EPREUVE : **INFORMATIQUE DE GESTION II**
NIVEAU : **2^{ème} ANNEE (S3)**
DATE : **21 JANVIER 2014**
DUREE : **2 HEURES**
RESPONSABLE : **M. Imad EL KHALKHALI**

Exercice 2

Graphe des Flux

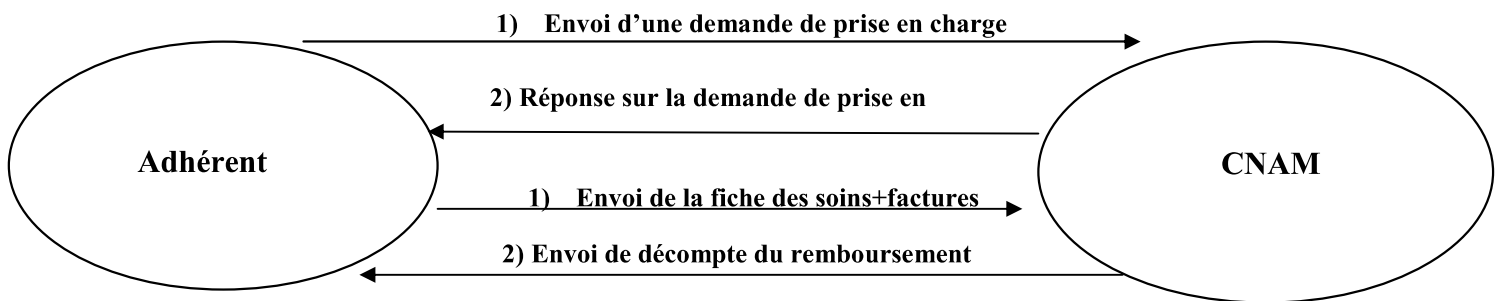

1er cas) MCT

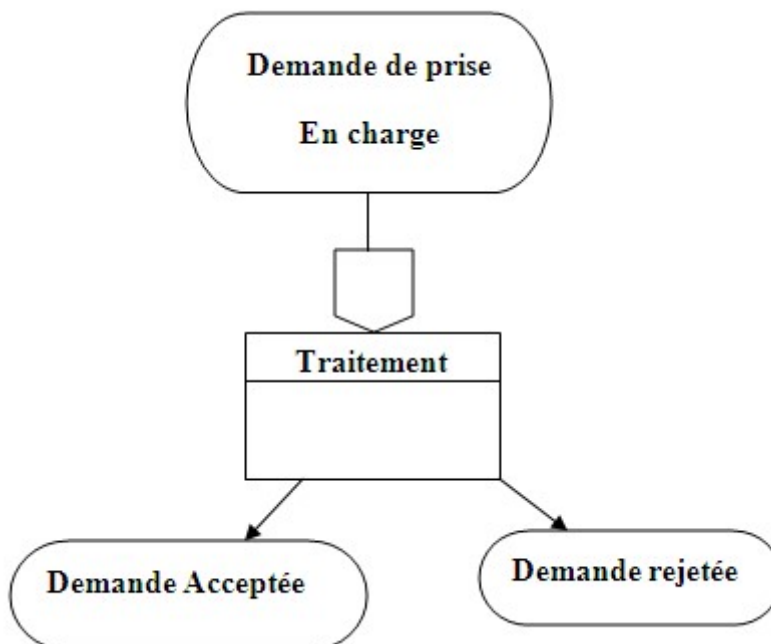

2ème cas) MCT

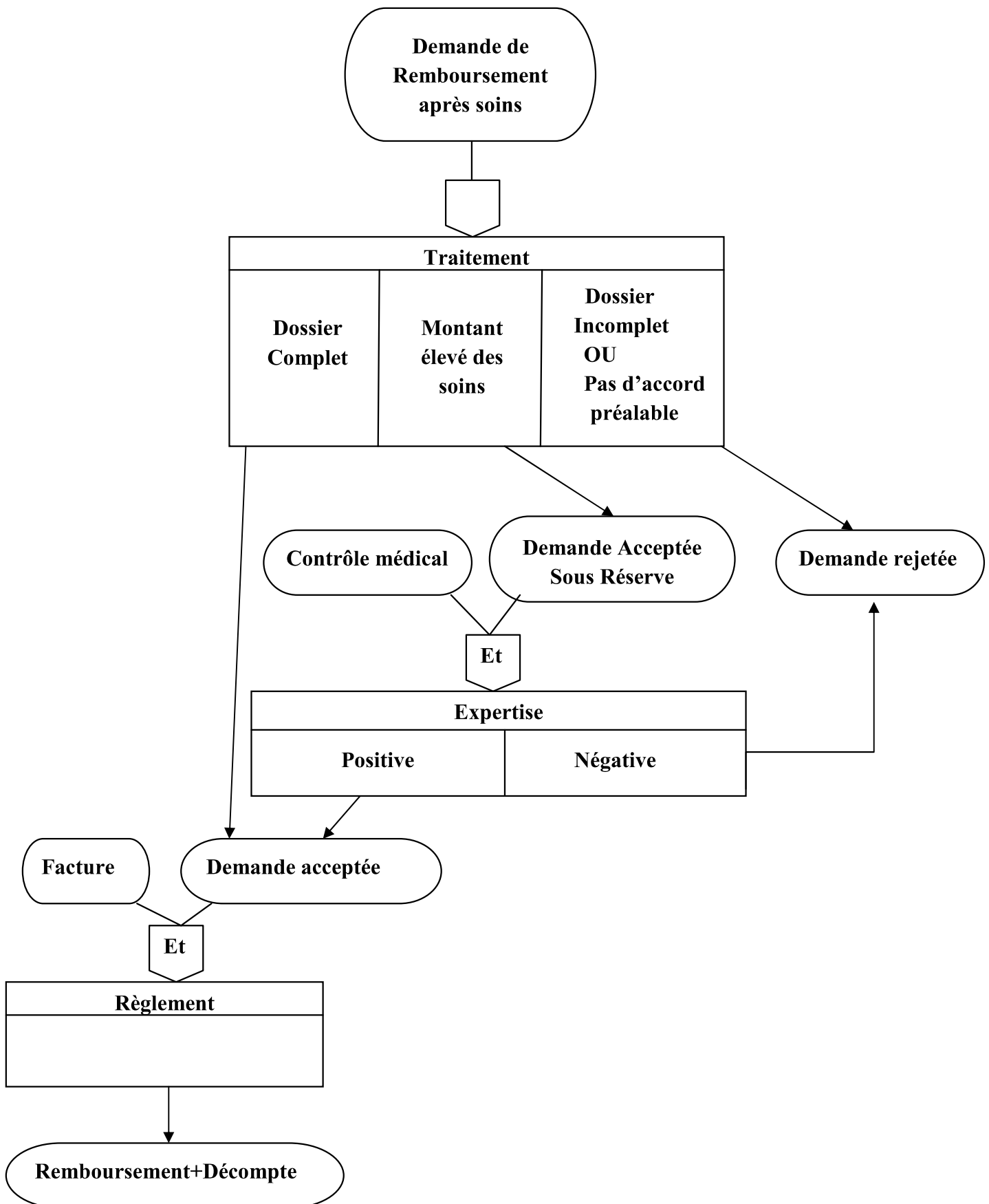

Exercice 3

Graphe des Flux

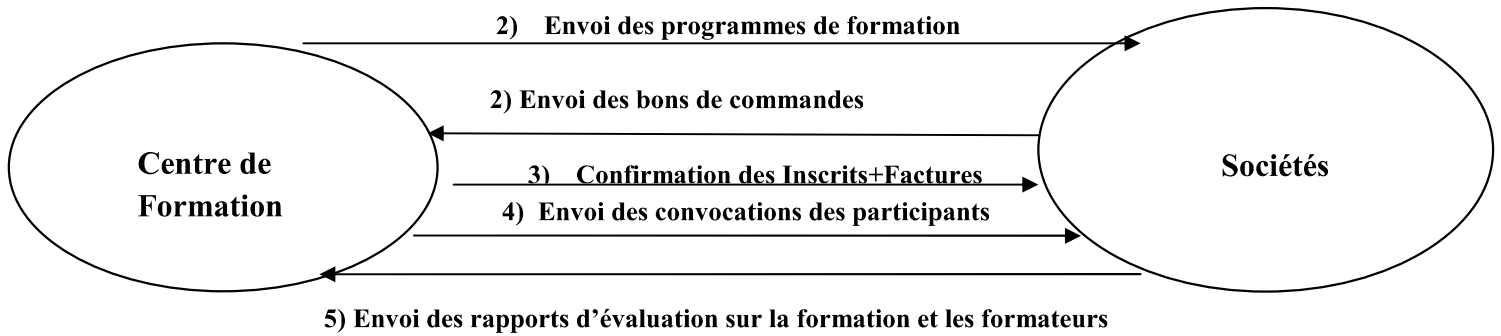

MCT

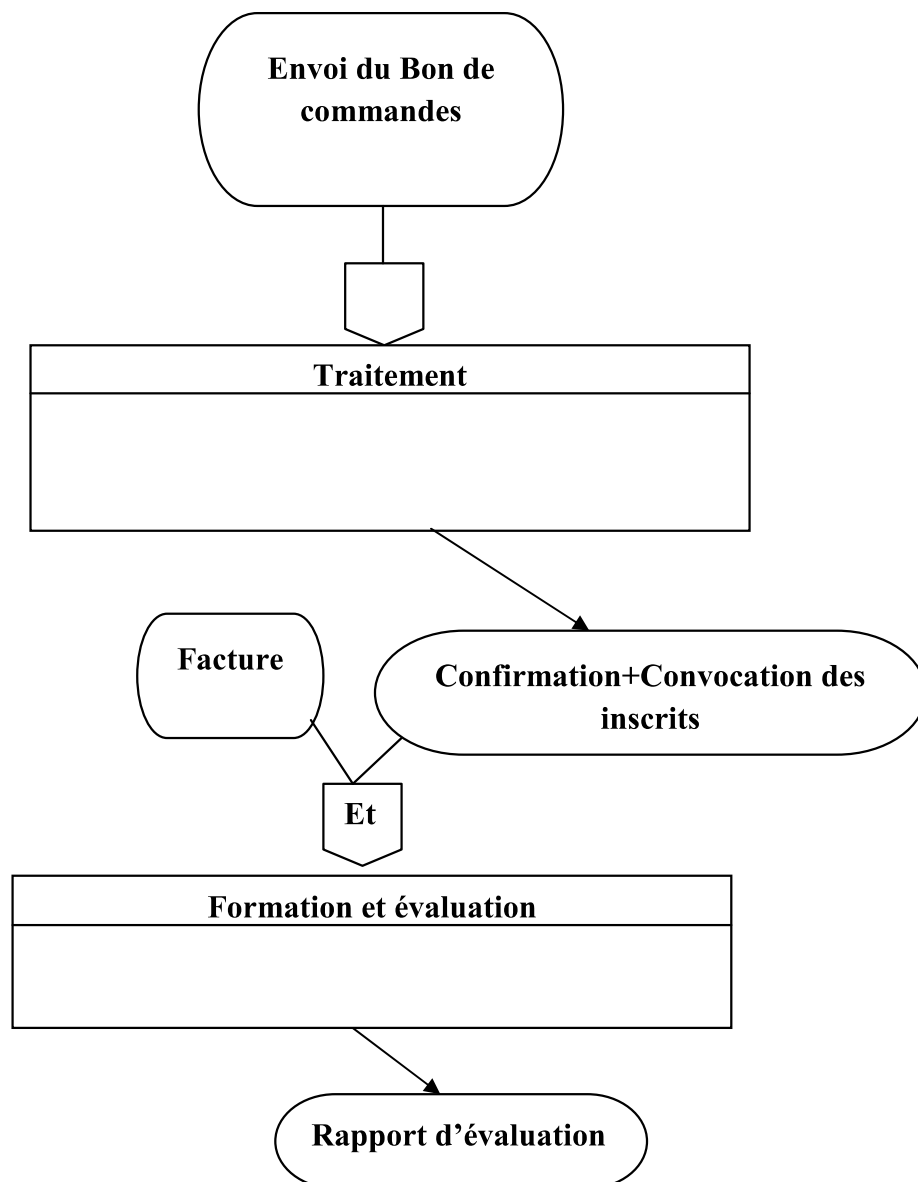

Exercice 1

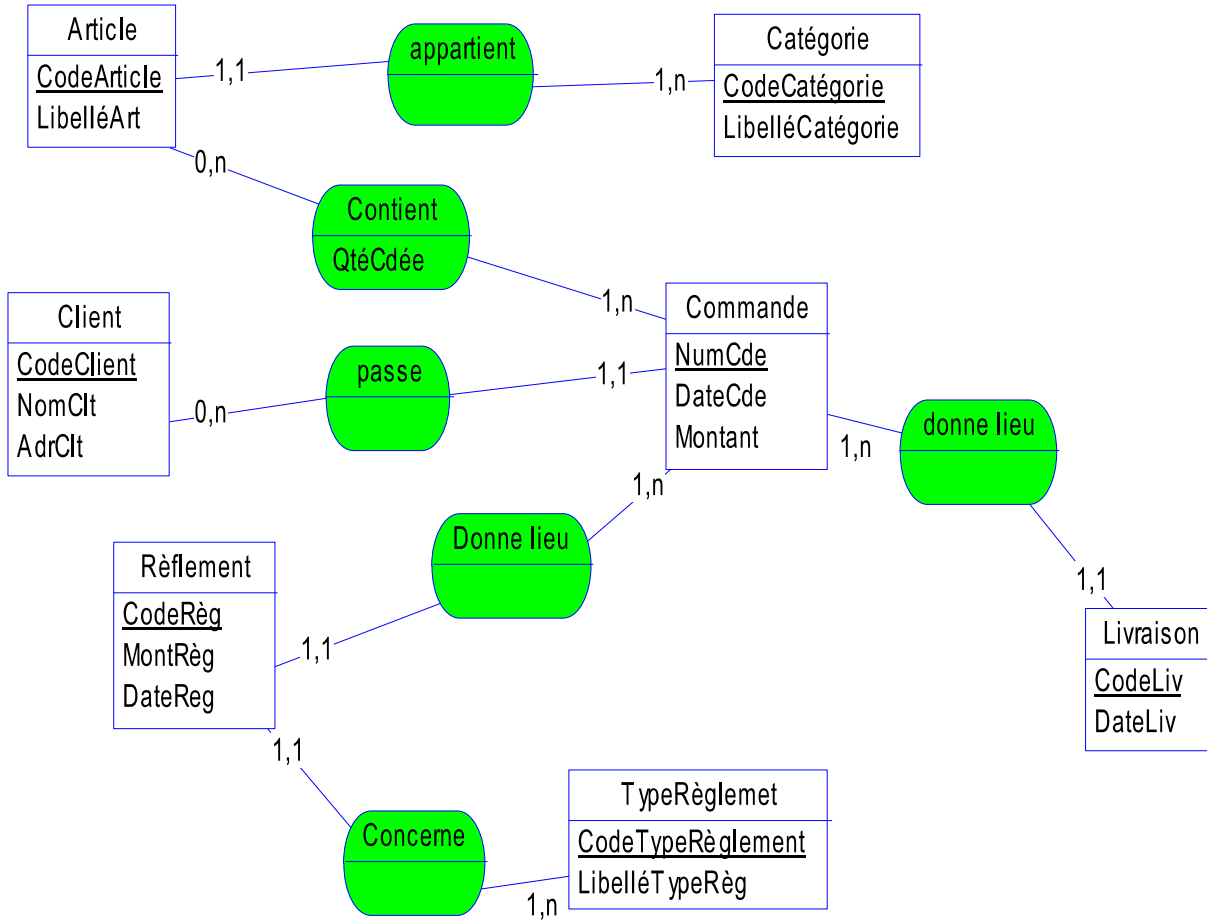

Exercice 4

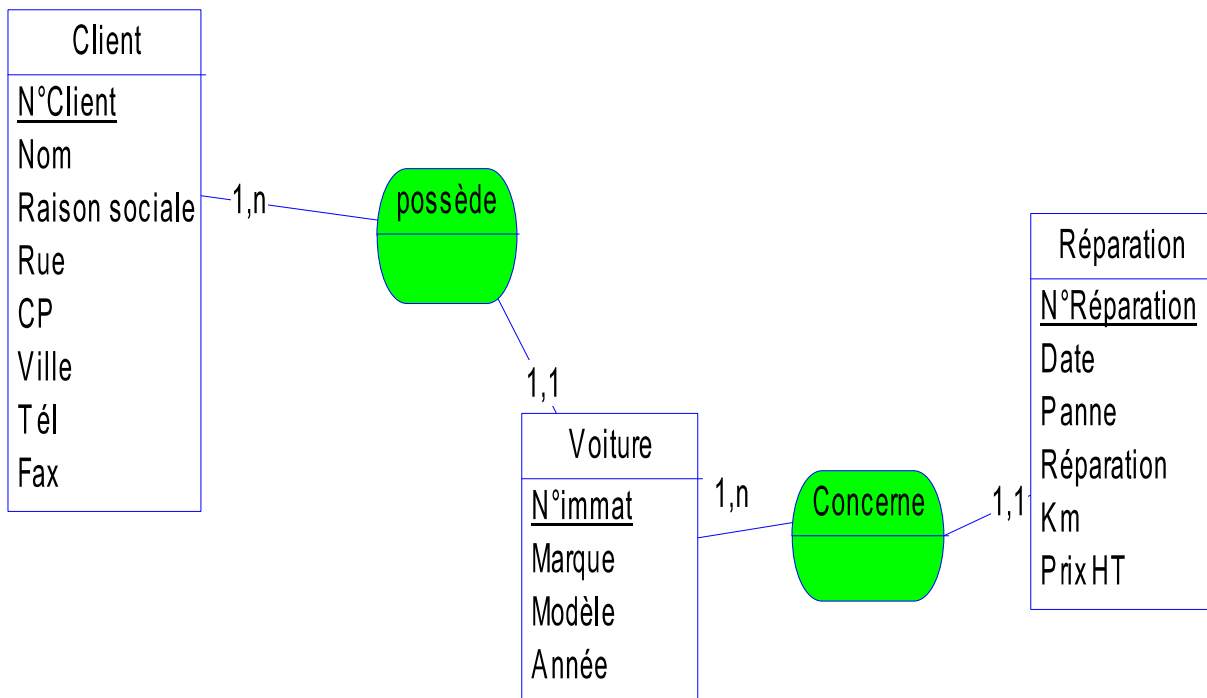

Client(Pas de changement)

Voiture(N°immat, #N°Client, Marque , Modèle, Année)

Réparation(N°Réparation, #N°immat, Date, Panne, Réparation, Km, Prix HT)